



## IPD TECH BULLETIN

### *Injector tip O-ring failure?*

November 2008

IPDTB-0017

You may have noticed on many of the later model engines, C-15, C-16, C-18, etc. that the seal O-ring at the injector tip has deteriorated. Some have questioned if the O-ring itself had failed and what the effects are.

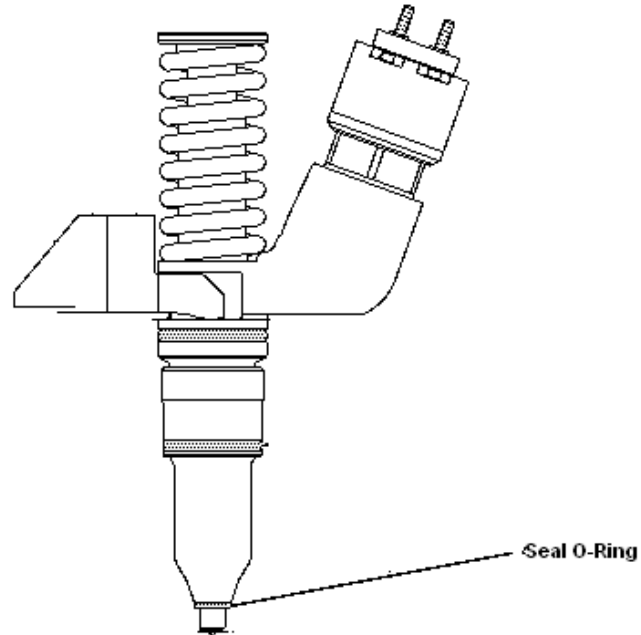

The function of the seal O-ring at the tip of these injectors is to seal long enough during the break in period for a "carbon dam" to be established. Once the "carbon dam" is in place the seal O-ring has serviced its purpose and due to the harsh conditions associated to this area of the engine the O-ring will deteriorate. This is a normal occurrence and does not affect the engine's performance or cause the injector to fail.

Continued...

In the photos below you will see the remainder of seal. It is normal for the O-ring to be burnt or damaged during engine operations.



Further supporting information can be found on OE publications SEBD6804 and SEBD9511

**IPD**  
Torrance CA USA 90501  
[www.ipdparts.com](http://www.ipdparts.com)

***IPD is an ISO9001:2000 Certified Company***

All information is believed to be accurate at time of printing. No guarantee of accuracy is made by IPD llc. Please consult your service and parts manual for detailed information. This is intended as a warning only, not a specification.

All manufacturers' names, numbers, symbols and descriptions are for reference only. It is not implied that any part is the product of the manufacturer. Caterpillar ® and Cat® are registered trademarks of Caterpillar, Inc

Copyright IPD LLC 2008